



Portable Air Conditioner User Manual

MODEL
CCPACA14*** / CCPACA14H***

1. READ these instructions carefully before installing and operating the appliance. Keep them for further reference.
2. Record in the space below the "SERIAL/MODEL NUMBER" found on the back or bottom of your appliance and retain this information for future reference.

SERIAL NUMBER:

MODEL NUMBER:

DATE OF PURCHASE:

Save and staple your sales receipt to your manual for warranty coverage.

CONTENTS

SAFETY INFORMATION

Important Safety Instructions.....	3-8
Safety Guidelines	6
Power Cord Operation.....	7
Specifications	7
Installation Guide Location	8

SET UP & USE

Parts & Features	8-9
Installation	10-12
Control Panel.....	13
Remote Control	14
Operation Instructions.....	15

CLEANING & CARE

Water Drainage	16
Start - End of Season Operations.....	17

TROUBLE SHOOTING & WARRANTY

Before You Call For Service.....	18
Customer Service.....	18
Troubleshooting.....	18
Limited Warranty.....	19

SAFETY INFORMATION



DANGER

DANGER - Immediate hazards which **WILL** result in severe personal injury or death



WARNING

WARNING - Hazards or unsafe practices which **COULD** result in severe personal injury or death



CAUTION

CAUTION - Hazards or unsafe practices which **COULD** result in minor personal injury

IMPORTANT SAFETY INSTRUCTIONS



WARNING

When using electrical appliances, basic safety precautions should be followed, including the following

1. Air conditioner must be connected to proper electrical outlet with the correct electrical outlet with the correct electrical supply.
2. Proper grounding must be ensured to reduce the risk of shock and fire. **DO NOT CUT OR REMOVE THE GROUNDING PRONG.** If you do not have a three-prong electric receptacle outlet in the wall, have a certified electrician install the proper receptacle. The wall receptacle **MUST** be properly grounded.
3. Do not operate air conditioner if power cord is frayed or otherwise damaged. Avoid using it if there are any cracks or abrasion damage along the length, plug connector or if the unit malfunctions or is damaged in any manner. Contact an authorized service technician for examination, repairs or adjustments.
4. **DO NOT USE AN ADAPTER OR AN EXTENSION CORD.**
5. Do not block airflow around the air conditioner. The exhaust hose should be free of any obstructions.
6. Always unplug the air conditioner before servicing it or moving it.
7. Do not install or use the air conditioner in any area where the atmosphere contains combustible gases or where the atmosphere is oily or sulphurous. Avoid any chemical coming in contact with your air conditioner.
8. Do not place any object on the top of the unit.
9. Never operate the air conditioner without filters in place.
10. Do not use the air conditioner near a bathtub, shower or wash basin.

SAVE THESE INSTRUCTIONS
HOUSEHOLD USE ONLY

SAFETY INFORMATION

HANDLING ALKALINE BATTERIES

WARNING

When handling alkaline batteries, basic safety precautions should be followed, including the following

1. Should fluid from the battery accidentally get into your eyes, there is a threat of loss of eyesight, do not rub them. Immediately rinse your eyes with clean tap water and then consult a physician immediately.
2. Do not put the battery in a fire, expose it to heat, dismantle or modify it. If the insulation or safety valve is damaged, the battery may leak fluid, overheat or explode.
3. Do not insert the battery with the poles reversed. Doing so may cause some abnormality or a short and the battery may leak fluid, overheat or explode.
4. Keep the battery out of the reach of children. If the battery is swallowed, contact a physician immediately.
5. If the alkali fluid gets in your mouth, rinse your mouth with water and contact a physician immediately.
6. If the alkali fluid gets on your skin or clothes, it may burn your skin, thoroughly rinse the affected area with tap water.
7. Do not mix new and old batteries or other makes of batteries. The different attributes may cause the battery to leak fluid, overheat or explode.
8. This battery was not made to be recharged. Recharging this battery may damage the insulation or internal structure and may cause the battery to leak fluid, overheat or explode.
9. Do not damage or remove the label on the exterior of the battery. Doing so may cause the battery to short, leak fluid, overheat or explode.
10. Do not drop, throw or expose the battery to extreme impact. Doing so may cause the battery to leak fluid, overheat or explode.
11. Do not alter the shape of the battery. If the insulation or safety valve is damaged, the battery may leak fluid, overheat or explode.
12. Immediately remove batteries when they have lost all power. Leaving the batteries in the unit for a long time may cause the batteries to leak fluid, overheat or explode due to gas that is generated by the batteries.
13. Remove the batteries from the unit when not using the unit for an extended period of time. The batteries may leak fluid, overheat or explode due to gas that is generated by the batteries.
14. Do not apply solder directly to the batteries. The heat may cause the batteries to leak fluid, overheat or explode.
15. Do not get the batteries wet. Doing so may cause the batteries to overheat
16. Store batteries someplace out of direct sunlight where the temperature and humidity are not high. Not doing so may cause the batteries to leak fluid, overheat or explode. Also, it may cause the life and performance of the batteries to decline.

SAFETY INFORMATION

17. Follow the regulations of the local government when disposing of these batteries.

SAVE THESE INSTRUCTIONS HOUSEHOLD USE ONLY

GROUNDING INSTRUCTIONS

ELECTRICAL REQUIREMENTS

The electrical requirements are a 115 volt 60 Hz, AC only, 15 amp. It is recommended that a separate circuit serving only the product be provided. The product is equipped with a 3-wire cord having a 3-prong grounding plug. It must be plugged into a wall receptacle that is properly installed and grounded.

This appliance must be grounded. In the event of an electrical short circuit, grounding reduces risk of electric shock by providing an escape wire for the electric current. The cord provided with this appliance is equipped with a grounding wire and a grounding plug. The plug must be plugged into an outlet that is properly installed and grounded.

Avoid the use of three prong adapters or cutting off the third grounding prong in order to accommodate a two prong outlet. This is a dangerous practice since it provides no effective grounding for the air conditioner and may result in shock hazard.

WARNING

Improper use of the grounding plug can result in a risk of electric shock.

Consult a qualified electrician or serviceman if:

- 1) The grounding instructions are not completely understood.
- 2) You are unsure that the appliance is properly grounded.
- 3) You have any questions about the grounding or electrical instructions.

POWER SUPPLY CORD

1. Avoid the use of an extension cord because of potential safety hazards under certain conditions. Have a qualified electrician or serviceman to install an outlet near the appliance.
2. If it is absolutely necessary to use longer cord sets or an extension cord, extreme care must be exercised.
 - a) Use only a grounding type 3-wire extension cord that has a 3-blade grounding plug and a 3-slot receptacle that will accept the plug on the appliance.
 - b) The marked electrical rating of the cord set or extension cord must equal to or greater than the electrical rating of the appliance. The longer cord should be arranged so that it will not drape over the counter top or table top where it can be pulled on by children or tripped over unintentionally.

NOTE: Neither W Appliance nor the dealer can accept any liability for damage to the product or personal injury resulting from failure to observe the electrical connection procedures.

SAFETY INFORMATION

SAFETY GUIDELINES

To prevent injury to the user or other people and property damage, the following instructions must be followed. Incorrect operation due to ignoring of instructions may cause harm or damage.

ALWAYS DO THIS	NEVER DO THIS	ENERGY SAVE
<ul style="list-style-type: none"> • Your air conditioner should be used in such a way that it is protected from moisture. e.g. condensation, splashed water, etc. Do not place or store your air conditioner where it can fall or be pulled into water or any other liquid. Unplug immediately. • Always transport your air conditioner in a vertical position and stand on a stable, level surface during use. • Turn off the product when not in use. • Always contact a qualified person to carry out repairs. If the supply cord is damaged it must be repaired by a qualified technician. • Keep an air path of at least 12 inches. all around the unit from walls, furniture and curtains. • If the air conditioner is knocked over during use, turn off the unit and unplug from the power supply immediately. 	<ul style="list-style-type: none"> • Do not operate your air conditioner in a wet room such as a bathroom or laundry room. • Do not touch the unit with wet or damp hands or when barefoot. • Do not press the buttons on the control panel with anything other than your fingers. • Do not remove any fixed covers. Never use this appliance if it is not working properly, or if it has been dropped or damaged. • Never use the plug to start and stop the unit. • Always use the switch on the control panel to start or shut off the unit. • Do not cover or obstruct the inlet or outlet grilles. • Do not use hazardous chemicals to clean or come into contact with the unit. Do not use the unit in the presence of inflammable substances or vapour such as alcohol, insecticides, petrol, etc. • Do not allow children to operate the unit unsupervised. • Do not use this product for functions other than those described in this instruction manual. 	<ul style="list-style-type: none"> • Use the unit in the recommended room size. • Locate the unit where furniture cannot obstruct the air flow. • Keep blinds/curtains drawn. • Keep the filters clean. • Keep doors and windows closed to keep cool air in and warm air out.

SAFETY INFORMATION

POWER CORD USE

The power supply cord contains a current device that senses damage to the power cord. To test your supply cord follow these steps:

1. Plug in the Air Conditioner.
2. The power supply cord head has two buttons, a TEST button and a RESET button. Press the TEST button and notice a click as the RESET button pops out.
3. Press the RESET button. Once again notice a click as the button engages.
4. The power supply cord will now supply electricity to the unit.

NOTE:

- Do not use this device to turn the unit on or off.
- Always make sure the reset button is pushed in for correct operation
- The power supply cord must be replaced if it fails to reset when either the test button is pushed, or it cannot be reset.
- If power supply cord is damaged, it cannot be repaired.
- It must be replaced by one obtained from the product manufacturer.

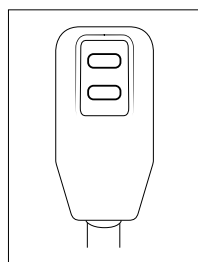

OPERATING CONDITION

The air conditioner must be operated within the temperature range indicated below:

MODE	ROOM TEMPERATURE
COOL	64°F (18°C) ~ 95°F (35°C)
DRY	64°F (18°C) ~ 95°F (35°C)
HEAT (ELECTRICAL HEAT TYPE)	45°F (7°C) ~ 81°F (27°C)

NOTE: Unit performance may be affected when in use outside of these operating temperatures.

SPECIFICATIONS

CCPACA14***/CCPACA14H***

- Unit Dimensions (W x D x H): 14" x 13" x 31.8"
- Unit Weight: Approx. 53 lbs./55 lbs.
- Electric Requirements: 115V ~ 60Hz

SAFETY INFORMATION

INSTALLATION GUIDE

LOCATION

- The air conditioner should be placed on a firm floor to minimize noise and vibration. For safe and secure positioning, place the unit on a smooth, level floor strong enough to support the unit.
- The unit has casters to aid placement, but it should be rolled on smooth, flat surfaces. Use caution when rolling on carpet surfaces. Do not attempt to roll the unit over objects.
- The unit must be placed within reach of a properly rated grounded socket.
- Never place any obstacles around the air inlet or outlet of the unit.
- Allow 12 inches to 36 inches of space from the wall with window for efficient air-conditioning.

SUGGESTED TOOLS FOR WINDOW KIT INSTALLATION

1. Screwdrivers (medium size Phillips)
2. Tape measure or ruler
3. Knife or scissors
4. Saw (In the event that the window kit needs to be cutdown in size because the window is too narrow for direct installation)

PARTS INCLUDED IN THE BOX

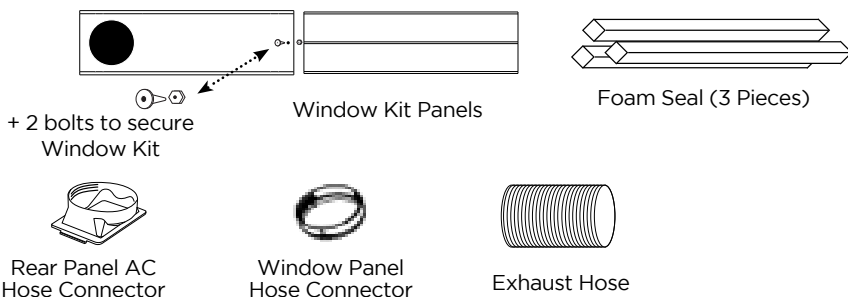

Remote Control Batteries not included

This device complies with part 15 of the FCC rules. Operation is subject to the following two conditions: 1) This device may not cause harmful interference, and 2) This device must accept any interference received, including interference that may cause undesired operation. This equipment has been tested and found to comply with the limits for a Class B digital device, pursuant to Part 15 of the FCC rules. These limits are designed to provide reasonable protection against harmful interference in a residential installation. This equipment generates, uses and can radiate radio frequency energy and, if not installed and used in accordance with the instructions, may cause harmful interference to radio communications. However, there is no guarantee that the interference will not occur in a particular installation. If this equipment does cause harmful interference to radio or television reception, which can be determined by turning the equipment off and on, the user is encouraged to try to correct the interference by one or more of the following measures: a) Reorient or relocate the receiving antenna. b) Increase the separation between the equipment and the receiver. c) Connect the equipment into an outlet different from that which the receiver is connected. d) Consult the dealer or an experienced radio/TV technician for help.

SET UP & USE

PARTS & FEATURES

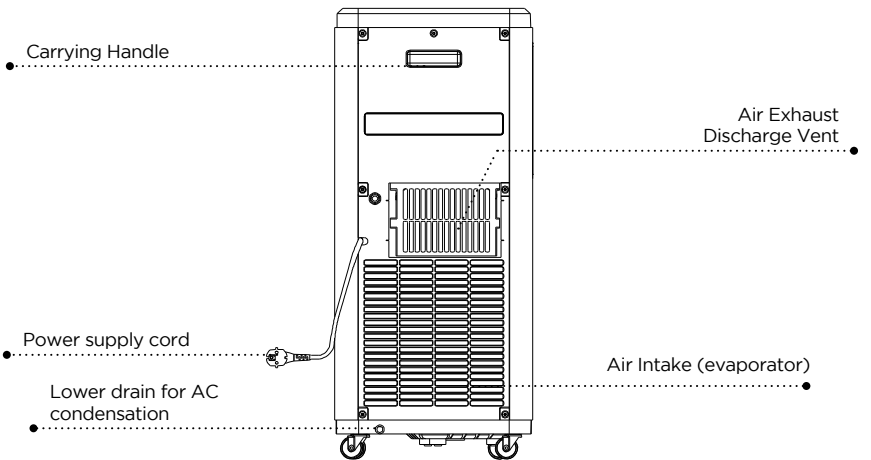
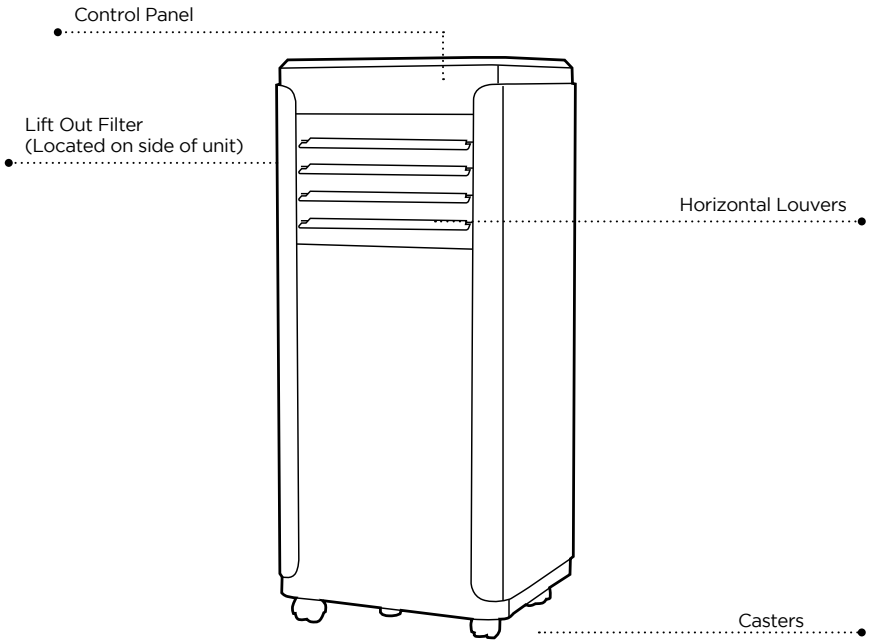

SET UP & USE

WINDOW SLIDER KIT INSTALLATION

Your window slider kit has been designed to fit most standard “Vertical” and “Horizontal” window applications; however, it may be necessary for you to improvise/modify some aspect of the installation procedures for certain types of window. Minimum and maximum window openings:

MINIMUM: 26.5 INCHES (67.5 CM)

MAXIMUM: 48 INCHES (123 CM)

Window slider kit can be secured by inserting the bolt.

Horizontal Window

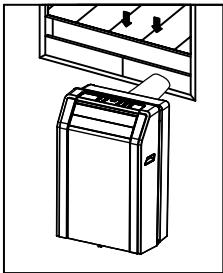

Vertical Window

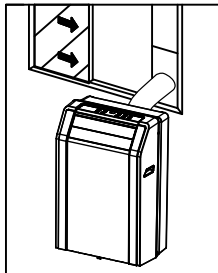

Window Slider Kit

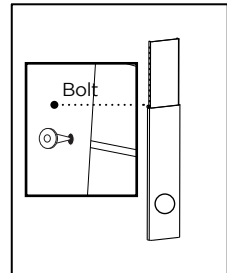

NOTE: If the window opening is less than the mentioned minimum length of the window slider kit, cut the one with a hole in it short to fit for the window opening. Never cut out the hole in window slider kit.

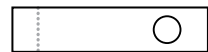

● Cut on opposite side of hole.

DOUBLE-HUNG SASH/SLIDING CASEMENT WINDOW INSTALLATION

1. Cut the foam seal (adhesive type) to the proper length and attach it to the window stool.
2. Attach the window slider kit to the window stool. Adjust the length of the window slider kit according to the width of window, shorten the adjustable window kit if the width of window is less than 26.5". Open the window sash and place the window slider kit on the window stool.
3. Cut the foam seal (adhesive type) to the power length and attach it on the top of the window.
4. Close the window sash securely against the window slider kit.
5. Secure the window slider kit to the window stool.
6. Cut the foam seal to an appropriate length and seal the open gap between the top window sash and outer window sash.

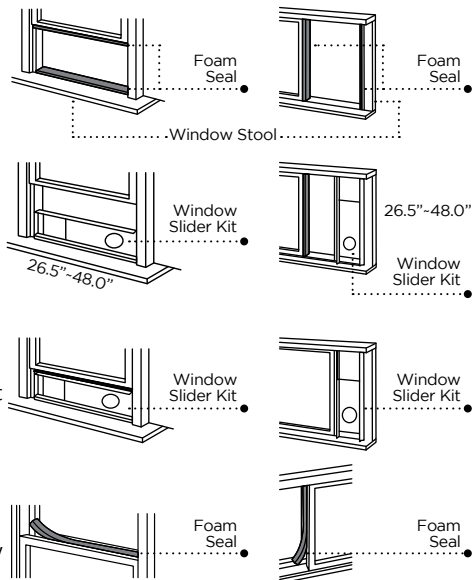

NOTE: Window Slider Kit can reach a minimum of 26.5" and a maximum of 48.0"

SET UP & USE

EXHAUST HOSE CONNECTORS

The exhaust hose and hose connectors must be installed or removed in accordance with the usage mode:

COOL, AUTO : Install

FAN, DEHUMIDIFY, HEAT (ELECTRICAL) : Remove

1. Install the hose connector over the air exhaust discharge vent by inserting the left side of the hose connector into the slots and then inserting the right side into the grooves. Push down to lock into place.
2. Push the exhaust hose into the hose connector as shown.
3. Insert the opposite end of the exhaust hose into the window panel hose connector.

NOTE: · The exhaust hose can be compressed or extended moderately, but it is desirable to keep the length to minimum. Also make sure that the hose does not have any sharp bends.

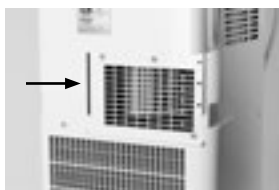

If difficulty occurs, compress hose ends & thread into connectors.

SET UP & USE

Take the Window Panel Hose Connector side of your exhaust hose and insert it into the window panel.

NOTE: The exhaust hose length should not be extended beyond the expanded length of the hose provided with the unit.

Plug the power cord into the wall outlet and press the “RESET” button.

Please allow 8” of space around the unit for proper air circulation.

. When removing the portable air conditioner for storage, the window panel may be left in place. Simply remove the exhaust hose assembly from the window panel and cover the window hole. .

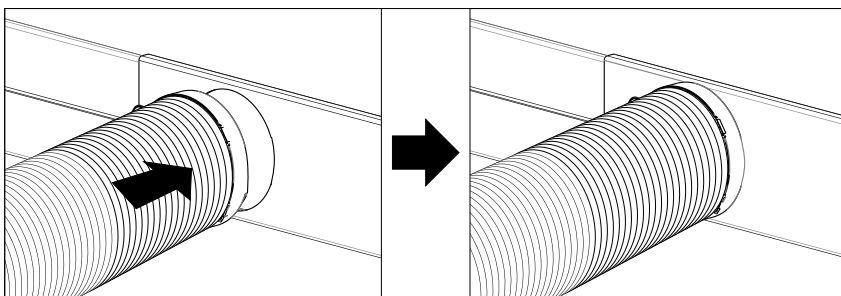

SET UP & USE

CONTROL PANEL

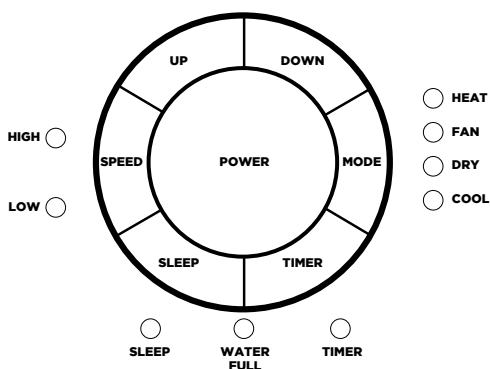

MODE BUTTON

Selects the appropriate operating mode. Each time you press the button, a mode is selected from COOL, DRY, FAN and HEAT. The mode indicator light illuminates under the different mode settings.

NOTE: Heat mode is only for models with heat options

TIMER BUTTON

Press the TIMER button when the unit is powered ON to set an AUTO START time.

When unit is ON Press the TIMER button to set an AUTO STOP time. Use the UP and DOWN buttons to set the time between 1-24 hours. The amount of hours will display on the LED display.

POWER BUTTON

Power switch ON/OFF.

SPEED BUTTON

Press SPEED to select either the HIGH or LOW fan speed when the unit is in fan mode. The HIGH or LOW fan speed indicator light will illuminate.

UP / DOWN BUTTON

Used to adjust (increasing/decreasing) temperature settings in a range of 62°F (17°C) to 90°F (32°C) or the TIMER setting in a range of 1-24 hours.

LED DISPLAY

Displays the set temperature in Fahrenheit. Displays Auto-timer settings and while in DRY and FAN modes displays room temperature.

SLEEP BUTTON

Once this setting is activated the air conditioner will automatically adjust the temperature for maximum comfort while you sleep.

SET UP & USE

REMOTE CONTROL

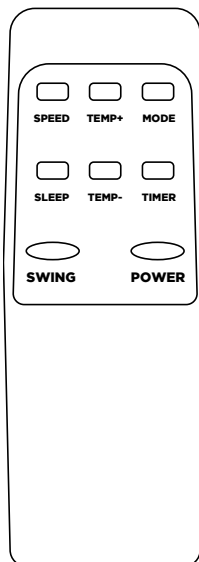

- POWER** Starts and stops operation.
- MODE** Each time the button is pressed, the operation mode COOL, DRY, FAN and HEAT is selected. **NOTE:** HEAT mode is for Cooling and heating models only.
- SPEED** Used to select the HIGH or LOW fan speed.
- TEMP+ BUTTON** Increase the indoor temperature setting to 90°F.
- TEMP- BUTTON** Decrease the indoor temperature setting to 62°F.
- TIMER** Timer on: Activate the Auto Start time setting when unit is powered OFF. Each press will increase the time setting in 1 hour increments up to 24 hours. To cancel the Auto Start setting, press the button until the time setting is 00
- TIMER OFF** Activate the Auto Stop time setting when the air conditioner is powered ON. Each press will increase the time setting in 1 hour increments up to 24 hours. To cancel the Auto Stop setting, press the button until the time setting is 00.
- SLEEP** Once this setting is activated the air conditioner will automatically adjust the temperature for maximum comfort while you sleep.
- SWING** Activates left/right air swing of the inner louver.

BATTERY INSTALLATION (BATTERIES NOT INCLUDED)

- (1) Slide open the battery compartment cover
- (2) Insert 2 x "AAA" batteries as shown.
- (3) Slide back the battery cover.

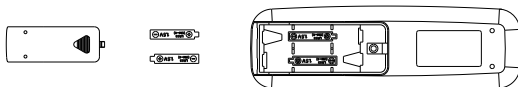

CAUTION: Use only AAA or IEC R03 1.5V alkaline batteries. Remove the batteries if the remote is not used for a month or longer. Do not attempt to recharge the batteries. Both batteries should be replaced at the same time. Do not dispose of the batteries in a fire as they may explode.

SET UP & USE

OPERATION INSTRUCTIONS

COOL OPERATION

- Press the “MODE” button until the “COOL” indicator light comes on
- Press the ADJUST buttons “UP” or “DOWN” to select your desired room temperature. The temperature can be set within a range of 62°F-90°F.
- Press the “SPEED” button to choose the fan speed.

HEAT OPERATION

(Applicable to the models with heat feature only)

- Press the “MODE” button until the “HEAT” indicator light comes on
- Press the ADJUST buttons “UP” or “DOWN” to select your desired room temperature. The temperature can be set within a range of 62°F-90°F.

DRY (DEHUMIDIFY) OPERATION

- Press the “MODE” button until the “DRY” indicator light comes on.
- Under this mode, you cannot select a fan speed or adjust the temperature. The fan motor operates at LOW speed.
- Keep window and door closed for the best dehumidifying effect.
- Exhaust hose attachment is not required in this mode.
- WATER FULL - When the water level reaches a predetermined level, the “water full” indicator light goes on. The unit will have to be drained.
NOTE: · Refer to Water Drainage section page 16.

FAN OPERATION

- Press the “MODE” button until the “FAN” indicator light comes on.
- Press the SPEED button to choose the fan speed. The temperature cannot be adjusted.
- Exhaust hose attachment is not required in this mode.

LED DISPLAY

Displays the set temperature in Fahrenheit. Displays Auto-timer settings and while in DRY and FAN modes displays room temperature.

Error codes and protection code:

E0: · Room temperature sensors error - Unplug the unit and plug it back in. If error repeats, call for service.

E2: · Bottom tray is full - Connect the drain hose and drain the collected water away. If error repeats, call for service

TIMER OPERATION

- When the unit is ON, first press the TIMER button, the TIMER indicator light illuminates. It indicates the AUTO STOP program is initiated.
- When the unit is OFF, first press the TIMER button, the TIMER indicator light illuminates. It indicates the AUTO START program is initiated.
- Continue to press the UP or DOWN button to change the AUTO TIME by 1 hour increments, up to 24 hours. The LED Display will indicate the remaining time.
- Turning the unit ON or OFF at any time or adjusting the timer setting to 00 will cancel the AUTO START/ STOP timed program.

CLEANING & CARE

WATER DRAINAGE

- During dehumidifying modes, remove the drain plug from the back of the unit, install the drain connector (5/8" universal female mender) with 3/4" hose (not included). For the models without drain connector, just attach the drain hose to the hole. Place the open end of the hose directly over the drain area over your basement floor or drip pan (not included).

Figure 2

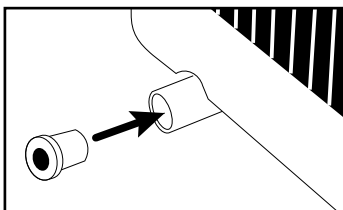

Figure 3

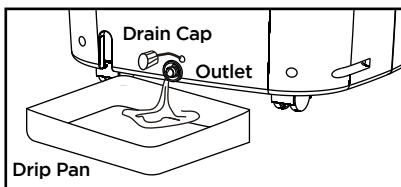
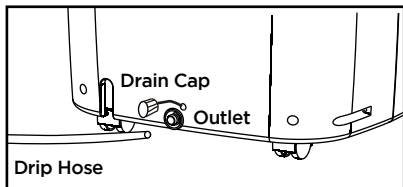

Figure 4



- When the water level of the bottom tray reaches a predetermined level, the WATER FULL indicator light goes on the digital display shows "E2." At this time, the air conditioning/dehumidification process will immediately stop. However, the fan motor will continue to operate (this is normal).

Carefully move the unit to a drain location, remove the bottom drain plug and let the water drain away. Restart the machine until the "E2" symbol disappears. If the error repeats, call for service.

NOTE: Be sure to reinstall the bottom drain plug before using the unit.

WAIT 3 MINUTES BEFORE RESUMING OPERATION

After the unit has stopped, it can not be restarted operation in the first 3 minutes. This is to protect the unit. Operation will automatically restart after 3 minutes.

* Always drain before storing unit for extended period.

CLEANING & CARE

⚠ DANGER

1. Be sure to unplug the unit before cleaning or servicing.
2. Do not use gasoline, thinner or other chemicals to clean the unit.
3. Do not wash the unit directly under a tap or using a hose. It may cause electrical danger.
4. If the power cord is damaged, it should be repaired by an authorized technician.

AIR FILTER

Clean the air filter at least once every two weeks to keep fan operation at its optimum efficiency. Grasp the filter tab and lift the filter out.

Figure 5



CLEANING

Wash the air filter by immersing it gently in warm water (about 104°F/40°C) with a neutral detergent. Rinse and dry the filter.

Re-install the air filter after cleaning.

UNIT ENCLOSURE

Use a lint-free cloth soaked with neutral detergent to clean the unit enclosure. Finished by a dry clean cloth.

EXTENDED UNIT STORAGE

- Remove the rubber plug at the back of the unit and attach a hose to drain outlet. Remove the plug from the bottom drain outlet, all the water in the bottom tray would drain out. (see picture on pg.16) Place the open end of the hose directly over the drain area in your basement floor.
- Keep the appliance running on FAN mode for half a day in a warm room to dry the appliance inside and prevent mold.
- Stop the appliance and unplug it, wrapped the cord and bundle it with the tape. Remove the batteries from the remote controller.
- Clean the air filter and reinstall it.
- Remove the exhaust hose. Cover the window hole or remove the window slider.

TROUBLESHOOTING & WARRANTY

BEFORE YOU CALL FOR SERVICE

IF THE AIR CONDITIONER FAILS TO OPERATE:

- A) Check to make sure that the air conditioner is plugged in securely. If it is not, remove the plug from the outlet, wait 10 seconds and plug it in again securely.
- B) Check for a blown circuit fuse or a tripped main circuit breaker. If these seem to be operating properly, test the outlet with another appliance.

IF NONE OF THE ABOVE SOLVES THE PROBLEM, CONTACT A QUALIFIED TECHNICIAN. DO NOT TRY TO ADJUST OR REPAIR THE AIR CONDITIONER YOURSELF.

CUSTOMER SERVICE

IMPORTANT

DO NOT RETURN THIS PRODUCT TO THE STORE

If you have a problem with this product, please contact the W Appliance Co. Customer Satisfaction Center at 1-855-855-0294.

**DATED PROOF OF PURCHASE, MODEL # AND SERIAL #
REQUIRED FOR WARRANTY SERVICE**

TROUBLESHOOTING

Troubleshoot your problem by using the chart below. If the air conditioner still does not work properly, contact W Appliance Co. customer service center or the nearest authorized service center. Customers must never troubleshoot internal components.

TROUBLE	ANALYSIS
Unit does not run at all	<ul style="list-style-type: none">• If the overheat safety feature is activated or a fuse is blown, the unit will not operate. Wait 3 minutes and try again as the overheat safety feature may be preventing the unit from working• If the batteries in the remote control are exhausted and need to be replaced• If the unit is not plugged in properly
Unit stops suddenly while running	<ul style="list-style-type: none">• If the SET temperature is too close to room temperature, lower the SET temperature• Air outlet may be obstructed. Clear the obstruction.
Unit is running but room is not cooling down	<ul style="list-style-type: none">• Check to see if door or window in the room is open• Check to see if there is another appliance generating heat such as a heater or lamp• The air filter is dirty and needs to be cleaned• The SET temperature is too high• Check to make sure exhaust hose is properly installed.• Make sure unit is set to Cool Mode.
Unit does not run and water full indicator light is on	<ul style="list-style-type: none">• Remove the water from the unit by opening the drain plug on the rear panel of the unit. If it still doesn't work, contact the Customer Satisfaction Center for assistance.
LED display "E0"	<ul style="list-style-type: none">• Temperature sensor error
LED display "E2"	<ul style="list-style-type: none">• Water tank full. Refer to water drainage instructions on page 16,

TROUBLESHOOTING & WARRANTY

LIMITED WARRANTY

Any repair, replacement, or warranty service, and all questions about this product should be directed to W Appliance Co. at **1 (855) 855-0294** from the USA or Puerto Rico.

W Appliance Co. warrants to the original purchaser that the product will be free from defects in material, parts and workmanship for the period designated for this product. The warranty commences the day the product is purchased and covers up to a period of **1 year (12 months) for labor/1 year (12 months) for parts (manufacturing defects only)/and a total of 5 years (60 months) for compressor part only.**

W Appliance Co. agrees that it will, at its option, replace the defective product with either a new or remanufactured unit equivalent to your original purchase during the warranty period.

Exclusions: This warranty does not apply to the below:

1. If the appearance or exterior of the product has been damaged or defaced, altered or modified in design or construction.
2. If the product original serial number has been altered or removed or cannot be readily determined.
3. If there is damaged due to power line surge, user damage to the AC power cord or connection to improper voltage source.
4. If damage is due to general misuse, accidents or acts of God.
5. If repair attempts are done by unauthorized service agents, use of parts other than genuine parts or parts obtained from persons other than authorized service companies.
6. On units that have been transferred from the original owner.
7. On products that have been purchased as refurbished, like new, second-hand, in a "As-Is" or "Final Sale" terms.
8. To products used in a commercial or rental setting.
9. To products used in settings other than ordinary household use or used other than in accordance with the provided instructions.
10. To damages for service calls for improper installations.
11. To glass parts and other accessory items that are included with the unit.
12. Transportation and shipping costs associated with the replacement of the unit.
13. Food loss for loss due to product failure or delay in service, repair or replacement.
14. Service calls to instruct you how to use your product.
15. Service calls to repair or replace the house fuse, reset the circuit breaker or correct the wiring in the house.

REPAIR OR REPLACEMENT AS PROVIDED UNDER THIS WARRANTY IS THE EXCLUSIVE REMEDY OF THE CUSTOMER; W Appliance Co. SHALL NOT BE LIABLE FOR ANY INCIDENTAL OR CONSEQUENTIAL DAMAGES FOR BREACH OF ANY EXPRESS OR IMPLIED WARRANTY ON THIS PRODUCT, EXCEPT TO THE EXTENT PROHIBITED BY APPLICABLE LAW. ANY IMPLIED WARRANTY OF MERCHANTABILITY OF FITNESS FOR A PARTICULAR PURPOSE ON THIS PRODUCT IS LIMITED TO THE DURATION OF THE WARRANTY.

Some states do not allow the exclusion or limitations of incidental or consequential damages, or limitations on how long the warranty lasts. In these cases the above exclusions or limitations may not apply to you. This warranty gives you specific legal rights and you may also have other rights which vary from state to state.

Obtaining Service: To obtain service, product literature, supplies or accessories please call

1 (855) 855-0294 to create a ticket for exchange/repair. Please make sure to provide the date of purchase, model number and a brief description of the problem. Our customer service representative will contact you or send detailed return instructions.

W Appliance Co. does not warrant that the appliance will work properly in all environmental conditions, and makes no warranty and representation, either implied or expressed, with respect to the quality, performance, merchantability, or fitness for a particular purpose other than the purpose identified within this user's manual. W Appliance Co. has made every effort to ensure that this user's manual is accurate and disclaims liability for any inaccuracies or omissions that may have occurred. Information in this user's manual is subject to change without notice and does not represent a commitment on the part of W Appliance Co.. W Appliance Co. reserves the right to make improvements to this user's manual and/or to the products described in this user's manual at any time without notice. If you find information in this manual that is incorrect, misleading, or incomplete, please contact us at **1-855-855-0294**.

W Appliance Co.,
1356 Broadway
New York, NY 10018



© 2018 Commercial Cool is a W Appliance Company.
All Rights Reserved.